

Innovation in soft start technology



# HFE-1

## USER MANUAL

# HFE-1 user guide

---

© **Motortronics UK Ltd**  
**Bristow House**  
**Gillard Way, Ivybridge**  
**PL21 9GG**  
**UK**  
**[www.motortronics-uk.co.uk](http://www.motortronics-uk.co.uk)**

© 2019 by Motortronics UK, all rights reserved

Copyright subsists in all Motortronics UK deliverables including magnetic, optical and/or any other soft copy of these deliverables. This document may not be reproduced, in full or in part, without written permission. Enquiries about copyright of Motortronics UK deliverables should be made to Motortronics UK Ltd. If, by permission of the copyright owner, any part of this document is quoted, then a statement specifying the original document shall be added to the quotation. Any such quotation shall be according to the original (text, figure or table) and may not be shortened or modified.

---

## Optimising Motor Control (iERS)

---

HFE Energy Saving soft starters are designed to control single phase AC motors. Operation is fully automatic - a low starting voltage is applied to the motor as soon as the supply is switched on. The internal automatic ramp control is immediately activated and raises the voltage progressively, causing the motor to accelerate smoothly.

At the end of the ramp period, the motor is operated in Energy Saving (iERS) mode and the HFE continuously regulates the voltage to match mechanical load. Energy consumption at light loads is reduced, motor winding and case temperatures are lowered, motor life is extended, noise levels are reduced, and power factor is improved.

Two LED's on the front of the unit indicate when the POWER supply is connected and when the unit is in iERS mode. As energy consumption is reduced the iERS LED flashes at a slower rate.

The HFE remains in circuit until the supply is disconnected. The HFE automatically resets and is ready for the next start.

---

## Safety

---

### Important information

Installers should read and understand the instructions in this guide prior to installing, operating and maintaining the soft start. The following symbols may appear in this guide or on the soft start to warn of potential hazards or to draw attention to certain information.



#### **Dangerous Voltage**

Indicates the presence of a hazardous voltage which could result in personal injury or death.



#### **Warning/Caution**

Indicates a potential hazard. Any instructions that follow this symbol should be obeyed to avoid possible damage to the equipment, and personal injury or death.



#### **Protective Earth (Ground)**

Indicates a terminal which is intended for connection to an external conductor for protection against electric shock in case of a fault.

**Caution Statements:** The examples and diagrams in this manual are included solely for illustrative purposes. The information contained in this manual is subject to change at any time and without prior notice. In no event will responsibility or liability be accepted for direct, indirect or consequential damages resulting from the use or application of this equipment.

**Short Circuit:** Motortronics UK soft starts are not short circuit proof. After severe overload or short circuit, the operation of the soft start should be fully tested by an authorised service agent.



HFE soft starts contain dangerous voltages when connected to the mains supply. Only qualified personnel that have been completely trained and authorised, should carry out installation, operation and maintenance of this equipment. Installation of the soft start must be made in accordance with existing local and national electrical codes and regulations and have a minimum protection rating. It is the responsibility of the installer to provide suitable grounding and branch circuit protection in accordance with local electrical safety codes. This soft start contains no serviceable or re-usable parts.

# Mechanical Details

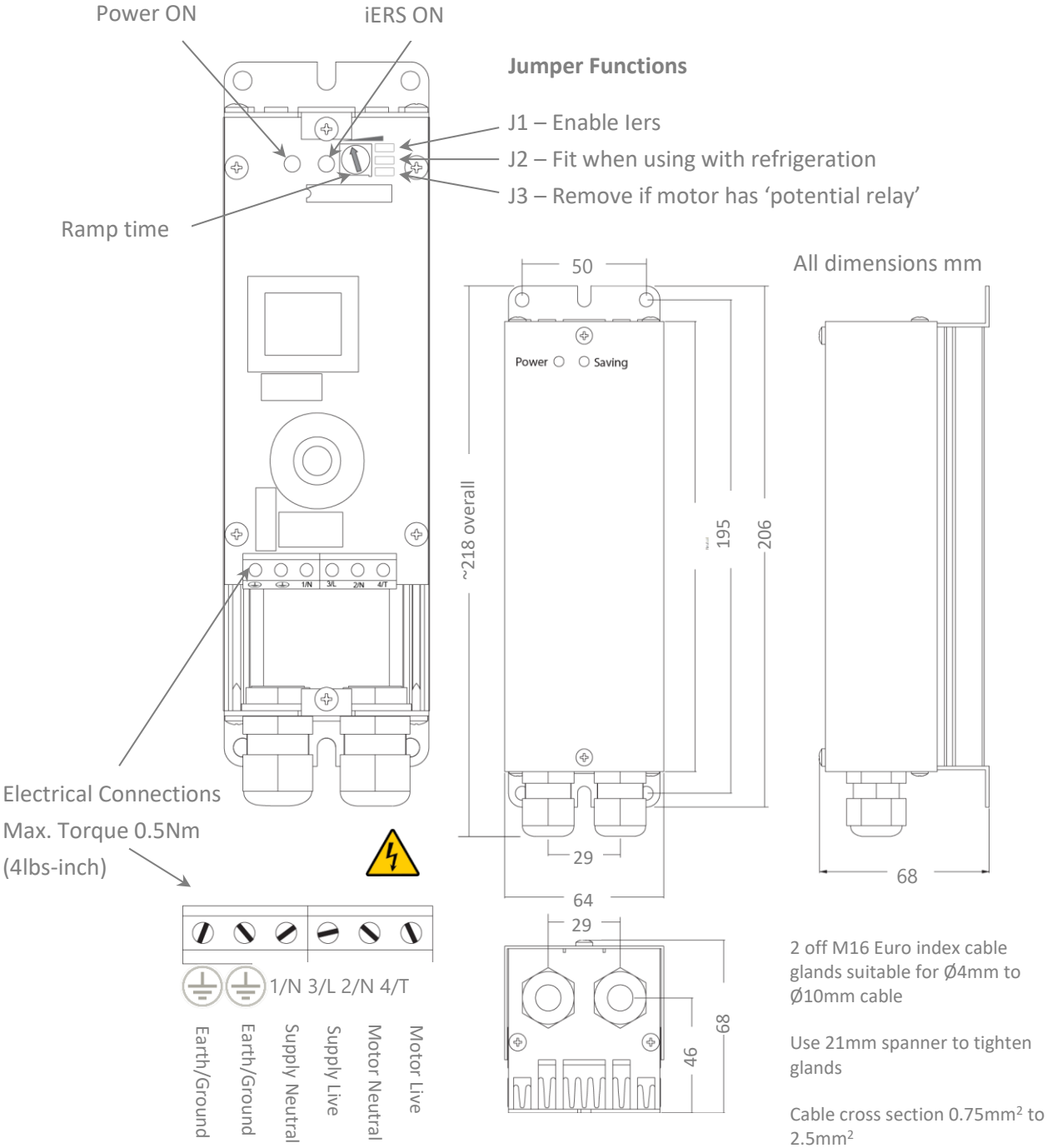

**MOUNTING**

The HFE module must be fixed to a vertical surface. To ensure free air movement a minimum clearance... The system may be configured to allow for auto restart controlled from contacts on the motor side of the unit. Users and operators must always take all necessary precautions to prevent damage to equipment and to prevent the risk of injury to personnel working on or near the motor and driven equipment.



## Electrical Wiring

The soft starter is normally inserted into the circuit between the motor and whatever switchgear is normally used for isolation or switching. The unit can also be fitted before switchgear so that it can be installed in the supply to equipment which has its own mechanical control. This feature allows for easy installation on equipment such as refrigeration where the need to disturb internal wiring is avoided.

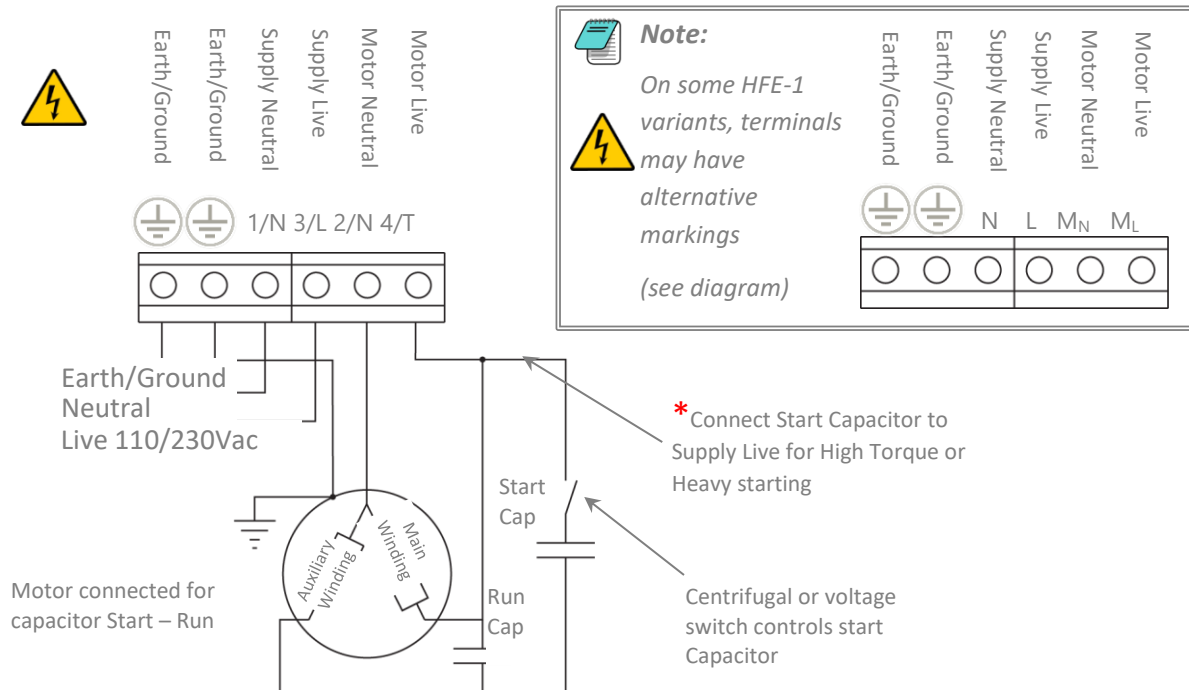

Extra starting torque may be needed for loads which have a particularly 'sticky' starting characteristic. This can be achieved by rearranging the internal connection of the starting capacitor, bringing the connection out and to the supply side of the starter as shown.

The terminations are made with industry standard cage clamp screw terminals directly onto the circuit board on all units.

The incoming power supply is connected to the terminals marked '1/N' and '3/L'. For EMC compliance it is important that the live circuit is connected to 3/L and the neutral circuit to 1/N.

Outgoing connections from the HFE are taken from the terminals marked '4/T' and '2/N' to the motor or load input terminals (see diagram). Ensure that a good connection is made to the earth terminals provided.

Fuses or other type of short-circuit protection are required for protection against a cable or motor terminal box fault. These must be fitted externally and on the supply side of the unit. See "Specifications" section for recommended fuse type and cut-out device.

## Operation

Set the ramp time potentiometer to midway to approx. 2 seconds and start the system. If the motor turns instantly when the soft starter is energised and accelerates satisfactorily then no further adjustment is required. If the rate of acceleration is too great, stop the unit and turn the ramp time potentiometer clockwise then restart. Adjust anti-clockwise for a shorter ramp time setting to increase the rate of acceleration. \*The motor should turn instantly when the soft starter is energised. If not, rearrange the connection of the starting capacitor as described above. For running currents up to and including 10 Amps the unit is rated for continuous duty.

Start currents must never exceed 60A

## Ratings and Specifications

### Rating Table

Load Amps (Ie)	Utilisation Category	Start		Duty	Up to Starts/Hr	Max. Fuse Rating *22x58mm class gR/aR	Cut-out Device
		Current (Amps)	Time (Secs)				
10	AC53a	30	4	99%	60	32A	10A MCB Trip Characteristic Type "C"
		<b>40</b>	<b>3</b>	<b>99%</b>	<b>10</b>		

\* 13A fused plug may be used for no more than a 5A load at duties indicated in the Rating Table

### IEC Rating Index

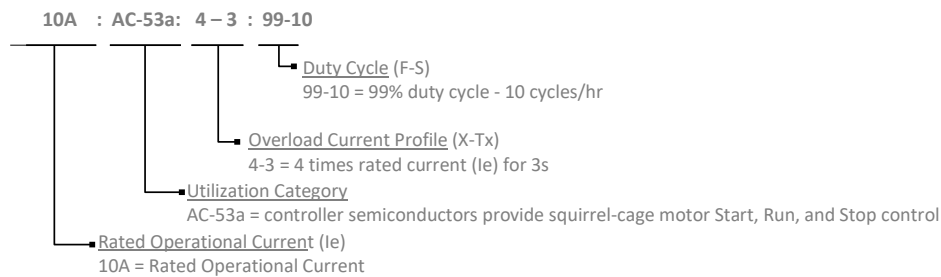

### Specifications

Pedestal Voltage:	Fixed at ~15%
Start Time:	Continuously variable from 0.5S -5S
Terminations:	Cage clamp terminals suitable for 0.75mm <sup>2</sup> (18 awg) to 2.5mm <sup>2</sup> (12 awg) solid or stranded wire
Ambient Temperature:	0°C to 40°C without derating
Enclosure:	IP20 with standard cover
Rated Operational Voltage:	Ue: 110 to 230V ac (-15% +10%), 50/60Hz
Recommended cut-out device:	10A rated MCB, Trip Characteristic "C"
Rated insulation voltage:	Ui: 250V
Rated impulse withstand voltage:	Uimp: 4kV (1.2 / 50µs)
Short circuit co-ordination:	Type 1 , Iq: 5kA when protected by recommended Fuse
Fuse Type:	See rating table.
Form designation:	Form 1
Pollution Degree:	2
EMC Emissions:	EN 55011 Environment B
EMC Immunity:	EN 60947-4-2
Design standards:	IEC 60947-4-2: "AC Semiconductor Motor Controllers and Starters"



<p><b>(en) Electric current! Danger to life!</b> Only skilled or instructed persons may carry out the operations.</p> <p><b>(de) Lebensgefahr durch Strom!</b> Nur Elektrofachkräfte und elektrotechnisch unterwiesene Personen dürfen die im Folgenden beschriebenen Arbeiten ausführen.</p> <p><b>(fr) Tension électrique dangereuse!</b> Seules les personnes qualifiées et averties doivent exécuter les travaux ci-après.</p> <p><b>(es) ¡Corriente eléctrica! ¡Peligro de muerte!</b> El trabajo a continuación descrito debe ser realizado por personas cualificadas y advertidas.</p> <p><b>(it) Tensione elettrica: Pericolo di morte!</b> Solo persone abilitate e qualificate possono eseguire le operazioni di seguito riportate.</p> <p><b>(zh) 触电危险!</b> 只允许专业人员和受过专业训练的人员进行下列工作。</p> <p><b>(ru) Электрический ток! Опасно для жизни!</b> Только специалисты или проинструктированные лица могут выполнять следующие операции.</p> <p><b>(nl) Levensgevaar door elektrische stroom!</b> Uitsluitend deskundigen in elektriciteit en elektrotechnisch geïnstrueerde personen is het toegestaan, de navolgend beschrevene werkzaamheden uit te voeren.</p> <p><b>(da) Livsfare på grund af elektrisk strøm!</b> Kun uddannede el-installatører og personer der er instruerede i elektrotekniske arbejdsopgaver, må udføre de nedenfor anførte arbejder.</p> <p><b>(el) Προσοχή, κίνδυνος ηλεκτροπληξίας!</b> Οι εργασίες που αναφέρονται στη συνέχεια θα πρέπει να εκτελούνται μόνο από ηλεκτρολόγους και ηλεκροτεχνίτες.</p> <p><b>(pt) Perigo de vida devido a corrente eléctrica!</b> Apenas electricistas e pessoas com formação electrotécnica podem executar os trabalhos que a seguir se descrevem.</p> <p><b>(sv) Livsfara genom elektrisk ström!</b> Endast utbildade elektriker och personer som undervisats i elektroteknik får utföra de arbeten som beskrivs nedan.</p>	<p><b>(fi) Hengenvaarallinen jännite!</b> Vain pätevät sähköasentajat ja opastusta saaneet henkilöt saavat suorittaa seuraavat työt.</p> <p><b>(cs) Nebezpečí úrazu elektrickým proudem!</b> Niže uvedené práce smějí provádět pouze osoby s elektrotechnickým vzděláním.</p> <p><b>(et) Eluohutlik! Elektrilöögioht!</b> Järgnevalt kirjeldatud töid tohib teostada ainult elektriala spetsialist või elektrotehnilise instrueerimise läbinud personal.</p> <p><b>(hu) Életveszély az elektromos áram révén!</b> Csak elektromos szakemberek és elektrotechnikában képzett személyek végezhetik el a következőkben leírt munkákat.</p> <p><b>(lv) Elektriskā strāva apdraud dzīvību!</b> Tālāk aprakstītos darbus drīkst veikt tikai elektrospeciālisti un darbam ar elektrotehnikām iekārtām instruētās personas!</p> <p><b>(lt) Pavojus gyvybei dėl elektros srovės!</b> Tik elektrikai ir elektrotechnikos specialistai gali atlikti žemiau aprašytus darbus.</p> <p><b>(pl) Porażenie prądem elektrycznym stanowi zagrożenie dla życia!</b> Opisane poniżej prace mogą przeprowadzać tylko wykwalifikowani elektrycy oraz osoby odpowiednio poinstruowane w zakresie elektrotechniki.</p> <p><b>(sl) Življenjska nevarnost zaradi električnega toka!</b> Spodaj opisana dela smejo izvajati samo elektrostrokovnjaki in elektrotehnično poučene osebe.</p> <p><b>(sk) Nebezpečenstvo ohrozenia života elektrickým prúdom!</b> Práce, ktoré sú nižšie opísané, smú vykonávať iba elektroodborníci a osoby s elektrotechnickým vzdelaním.</p> <p><b>(bg) Опасност за живота от електрически ток!</b> Операциите, описани в следващите раздели, могат да се извършват само от специалисти-електротехници и инструктиран електротехнически персонал.</p> <p><b>(ro) Atenție! Pericol electric!</b> Toate lucrările descrise trebuie efectuate numai de personal de specialitate calificat și de persoane cu cunoștințe profunde în electrotehnică.</p>
--	---

#### California Customers: California Proposition 65 Warning

WARNING: this product and associated accessories may contain chemicals known to the State of California to cause cancer, birth defects, or other reproductive harm.

For more information visit <https://p65warnings.ca.gov>