



Current Transformer

Model IE93L
rev 032916

CERTIFICATIONS:



APPLICATION:

Metering

FREQUENCY:

50/60 Hz.

INSULATION LEVEL:

720 Volts. 10 kV BIL. full wave

APPROXIMATE WEIGHT:

0.45 kg

CONNECTIONS:

Secondary terminals screw clamp up to 10mm² cable. 'Fast on' 6.3mm type. Integral Terminal Cover IP20B

ENCLOSURE CODE:

IP40

INSULATION CLASS:

Class E BS2757 IEC85

COMPLIES WITH / APPROVALS:

IEC60044-1:2003 / BSEN61010-1, EN60044-1

MOUNTING HARDWARE OPTION:

Order p/n: IE93L-FIXING-KIT



Model	IE93L
Window Size	50 x 10mm 40 x 30mm 42mm diameter
Width	90mm
Height	131mm
Depth	30mm

MODEL IE93L

CATALOG NUMBER	CURRENT RATIO	VA at Class 3	VA at Class 1	VA at Class 0.5
IE93L-400/5	400:5	15	7.5	3.75
IE93L-500/5	500:5	20	15	5
IE93L-600/5	600:5	30	20	10
IE93L-750/5	750:5	20	15	7.5
IE93L-800/5	800:5	20	15	10
IE93L-1000/5	1000:5	20	20	15
IE93L-1200/5	1200:5	30	30	20
IE93L-1250/5	1250:5	30	30	20
IE93L-1500/5	1500:5	30	30	20
IE93L-1600/5	1600:5	30	30	20

Note: Change the end suffix to depict required secondary. For example IE93L-750/1.

DIMENSIONS

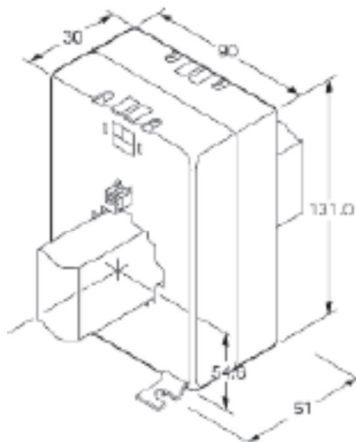

Products are manufactured in a plant whose quality management system is certified / registered as being in conformity with ISO 9001